



The Veflex VRE125SF is a very narrow aisle truck, based on the successful technology of the Reflex reach truck. It is equipped with everything needed for heavy duty and high performance very narrow aisle (VNA) handling.



email: info@forstor.com.ua

site: www.forstor.com.ua



Technical Details		VRE125SF
Power unit		electrical, battery
Rated capacity	kg	1250
Load centre	mm	600
Weight without battery	kg	3950 ¹⁾
Wheel type		polyurethane
Wheel dimension, fork side	mm	230x85/230x110
Wheel dimension, drive wheel side	mm	350x150
Number of wheels, fork side		4
Number of wheels, drive wheel side		1
Travel speed, without/with rated load	km/h	12/12 — 9/9 ²⁾
Lift speed, without/with rated load	m/s	0.37/0.30
Lowering speed, without/with rated load	m/s	0.48/0.50
Service brake		electro-regenerative
Parking brake		electro-mechanical
Drive motor/Intermittent rating	kW/%	7.5/60
Lift motor/Intermittent rating	kW/%	14/15
Battery weight	kg	940—1400
Battery (5h discharge)	V/Ah	48/480—900
Steering system		electronic power steering
Speed control, number of steps		electronic, stepless

Dimensions, mm		VRE125SF
y	Wheel base	2157/2557
b ₁₀	Track width front c/c	1143/1220
h ₆	Height of cab	2266
h ₇	Height of driver's seat	1100
h ₁₃	Height of lowered fork	365 +/- 5
l ₁	Total truck length	2710/3110
l ₂₂	Fork carrier back to c/c fork	500/595/695
b ₁	Chassis, width	1375/1490
s	Fork thickness	75
e	Fork width	180
l	Fork length	1100—1400
b ₅	Width across fork	550
m ₂	Floor clearance mid wheelbase	60
W _a	Turning radius	2400/2800

1) h₂₃ = 7300 mm, l₁ = 2710 mm, b₁ = 1490 mm

2) 12/12 km/h for chassis width 1490mm when rail guided. 9/9 km/h for chassis width 1375mm, or chassis width 1490mm when wire guided.

Mast, mm		VRE125SF										
h_{23}	Total lift height	4600	5200	5800	6400	7300	7900	8500	9100	9700	10300	11300
Triplex Hi-Lo												
h_1	Height of mast, min.	2535	2735	2935	3135	3570	3770	3970	4170	4505	4705	5035
h_2	Free lift	1490	1690	1890	2090	2524	2724	2924	3124	3458	3658	3990
h_4	Height of mast, max.	5265	5865	6465	7065	7965	8565	9165	9765	10365	10965	11965

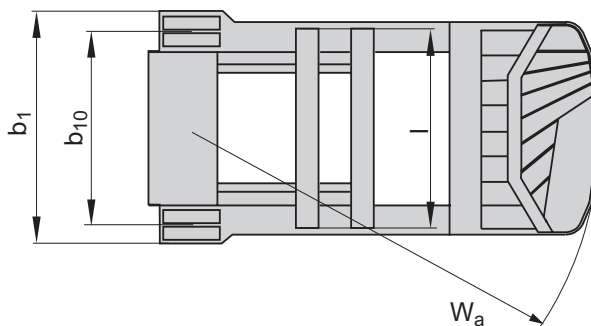
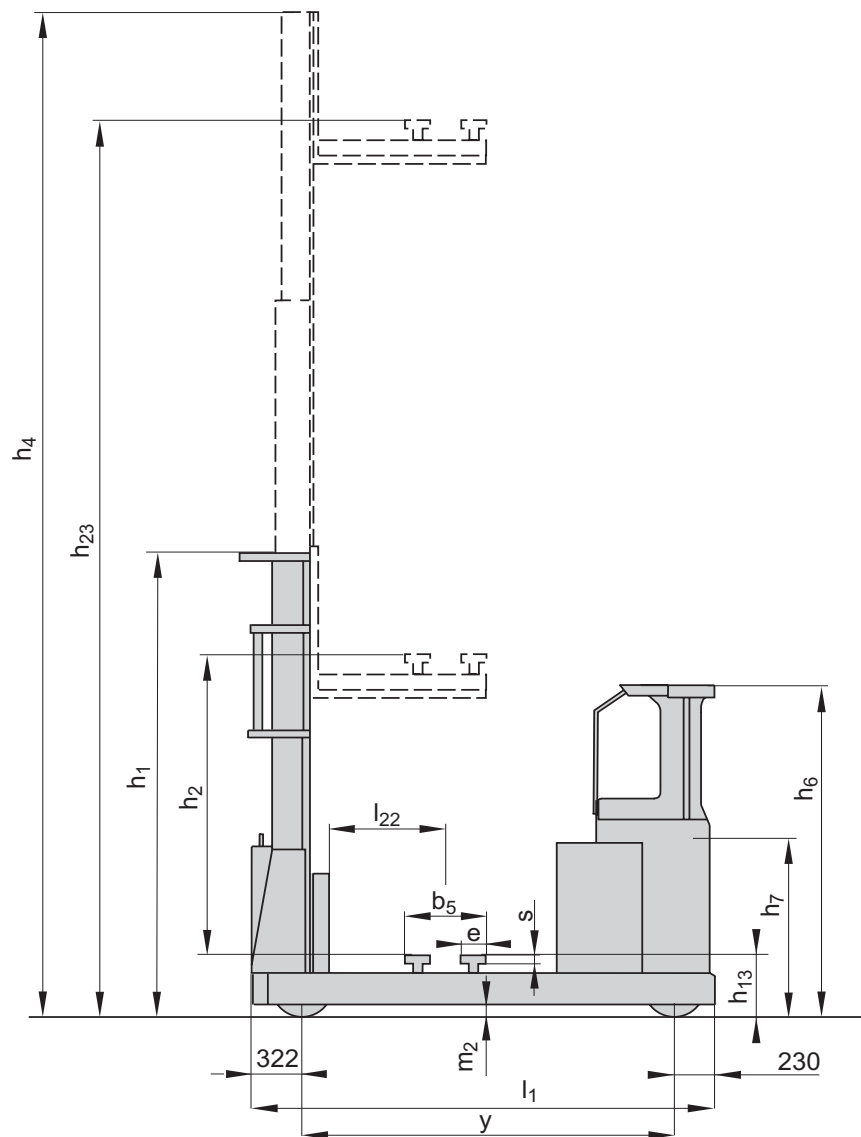

Truck performance and dimensions are nominal and subject to tolerances.
 BT Products AB products and specifications are subject to change without notice.
 All data is based on VDI 2198.



- The VRE125SF handles open entry pallets, placing the shuttle forks between the mast and the driver, which assures good stability and an excellent view of the load.
- Excellent driver ergonomics, with fully adjustable seat, BT Control console and electronic controls for all hydraulic functions.
- Available with rail or wire guidance. The smart wire guidance system learns different frequencies by driving the truck on the wire.
- Optimal power-to-weight ratio is achieved by configuring the truck to the application with different chassis widths, lengths and counterweights.
- E-bar. Universal mount for warehouse management devices such as PC:s, terminals, bar code readers etc.

Truck features	VRE125SF
Choice of chassis widths	S
Shuttle fork version	S
Wire/rail guidance	O
Controls and instruments	
Electronic height indicator	S
Power/electronic steering	S
Steering direction indicator	S
Weight indicator	S
Driving features	
360° progressive steering	S
Automatic deceleration	S
Electronic braking system	S
Electronic speed control	S
Safety features	
Automatic parking brake	S
Clear-view overhead guard	S
Programmable performance	S
Drivers compartment features	
Adjustable pedals	S
Adjustable seat	S
Adjustable steering wheel	S
On-board data terminal mount (E-bar)	S
Maintenance features	
Fault diagnosis facility	S
History fault log	S
Battery management features	
Battery status indicator	S
Side-ways battery change	S
Special applications	
Coldstore version	O

S = Standard feature

O = Optional feature

— = Not available